



cod.11630205 GB
rev.01
(software VER. 1.50)



USER INSTRUCTIONS *Controller*

(EQUIPMENT FOR ELECTRONIC CONTROL OF SELF-PROPELLING IRRIGATORS.)

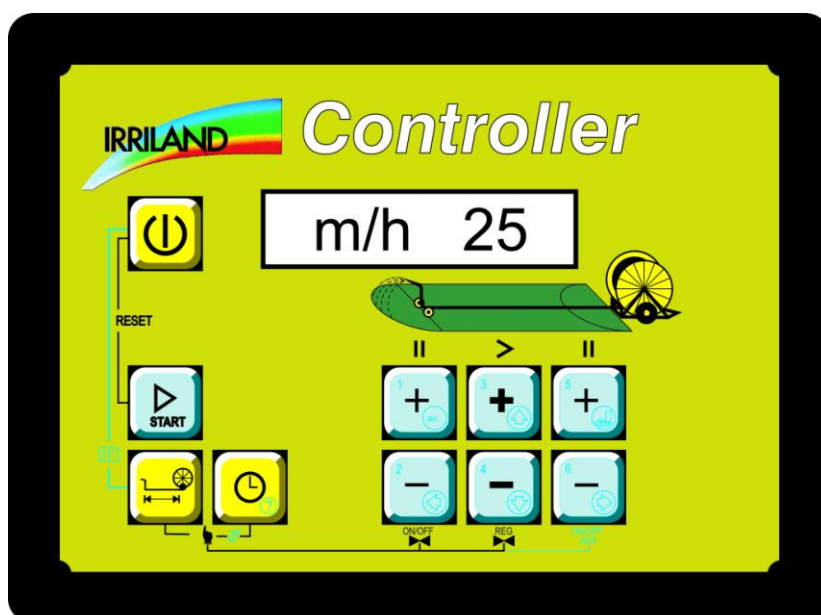

IRRILAND s.r.l. 42016 GUASTALLA (RE) Italy – via Togliatti, 4
tel. ++39 0522 831544 Internet : Web <http://www.irriland.it>
fax ++39 0522 831548 e-mail: info@irriland.it

UNIVERSAL SALES

USA PNW Representative
www.universalsales.biz



TABLE OF CONTENTS:

TABLE OF CONTENTS: 1

1. GENERAL FEATURES..... 2

2. OPERATING FEATURES..... 3

2.1 Key functions..... 3

2.2 Regulation of the display’s contrast..... 7

2.3 CLOCK 8

2.3.1. Setting the day and time in hours and minutes. 8

2.4. Programming 9

2.4.1. Irrigation parameters 9

3. IRRIGATION CYCLE 10

3.1 Switching on the CONTROLLER control box 10

3.2 Unrolling of the pipe 10

3.2.1. Manual change or entry of the amount of unrolled metres..... 11

3.3 Programming the Winding Speed..... 11

3.4 Programming the Initial Pause..... 12

3.5 Programming the Final Pause 12

3.6 Programming the Irrigation Time 13

3.7 Start of the Irrigation Cycle 13

3.7.1 Displays during irrigation 13

3.7.2 Possible anomalies during Irrigation Cycle..... 14

3.8 End of the Irrigation Cycle 14

4. TEST and MANUAL PROCEDURE 16

4.1 Outlet test 16

4.2 Test of battery voltage, sensors, relays, input and output extra sources. 16

5. CONNECTIONS 18

STANDARD CONNECTIONS..... 18

AUXILIARY CONNECTIONS 18

6. REGULATIONS 19

1. GENERAL FEATURES

Controller is designed to control the initial irrigation time without rewinding, the irrigation trolley retraction speed and the final irrigation time without rewinding and to open and close the water flow for efficient irrigation.

Controller is composed by a control box with a 10-key keypad and a backlit 8-large character display.

Controller works at 12 V DC power (usually connected to a battery).

The average consumption during irrigation is about 25 ma.

The maximum applicable load for regulation is 4 A.

The following devices can be connected to Controller:

- Speed sensor, generally mounted on the gear or on the “pipe-feeler” roll;
- Pressure switch for pressure control in the pipe (optional);
- Valve control for trolley retraction speed control;
- Valve control to open and close the water flow;
- Rewinding limit switch;
- Wind speed sensor (optional anemometer)
- Pressure sensor (optional pressure transducer)
- Stop device of the motor pump or of the endothermic or rewinding motor;
- IN and OUT signals for telephone alarm.

2. OPERATING FEATURES

Controller uses both metric and imperial systems.

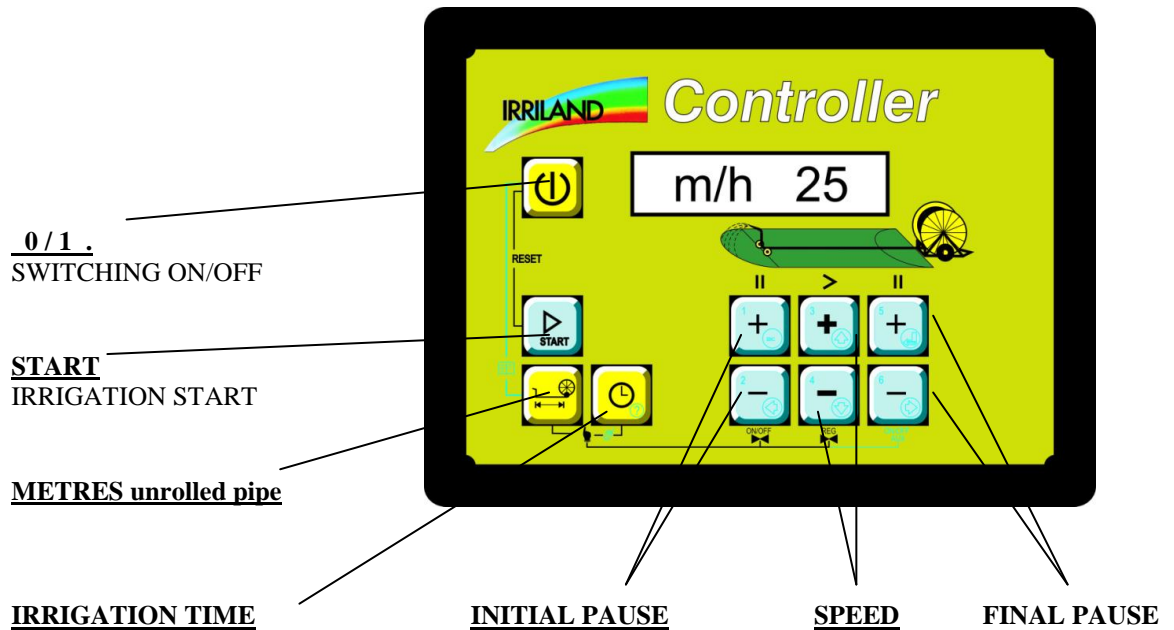

2.1 Key functions

Controller is equipped with a 10-key keypad enabling the use of the device.

Except for the ON/OFF key all other keys serve several functions depending on the intensity of the pressure exerted: SHORT, LONG and CONTINUOUS.

A SHORT pressure enables displaying the key function or the single datum variation.

A LONG pressure (1 second) enables programming the corresponding feature.

A CONTINUOUS pressure enables a continuous and rapid increase or decrease of the feature value.

At every key pressure the display is backlighted and remains active for about 8 seconds from the last key pressure.

ON/OFF key



- Switching on/off of the Controller control box.

START key



| | |
|----------------------------|--|
| - SHORT pressure | - Displays current datum - Exits TEST mode |
| - LONG pressure | - Starts irrigation cycle. |
| - Pressure at SWITCHING ON | - RESET - Starts a new cycle leaving the uncompleted one |

METRES unrolled pipe key

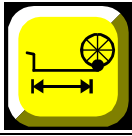

| | |
|--|---|
| - SHORT pressure | - Displays the amount of metres of unrolled pipe. |
| - LONG pressure | - Enables programming the metres of unrolled pipe (the symbol * on the left side of the display shows the beginning of the programming process). To introduce changes use + or - key of the Initial and Final Pause and of the Speed. |
| - Simultaneous pressure of the IRRIGATION TIME key | - Accesses TEST mode |

NOTE: in this manual it is referred to by using the symbol **_m_**

IRRIGATION TIME key



| | |
|--|--|
| - SHORT pressure | - Displays irrigation time expressed in hh:mm (hours and minutes). - If the clock function is active, the irrigation end time is displayed |
| - LONG pressure | - Enables programming the irrigation time. (the symbol * on the left side of the display shows the beginning of the programming process). To introduce changes use speed keys (>) + or - |
| - Simultaneous pressure of the METRES unrolled pipe key: | - Accesses TEST mode. |

NOTE: in this manual it is referred to by using the symbol **_h_**

INITIAL PAUSE key +



| | |
|-----------------------|---|
| - SHORT pressure | - Displays the duration of the programmed INITIAL PAUSE expressed in minutes. - In INITIAL PAUSE programming mode, single minute increase. |
| - LONG pressure | - Enables programming the INITIAL PAUSE. (the symbol * on the left side of the del display shows the beginning of the programming process). |
| - CONTINUOUS pressure | - In INITIAL PAUSE programming mode, fast minute increase. |

INITIAL PAUSE key -

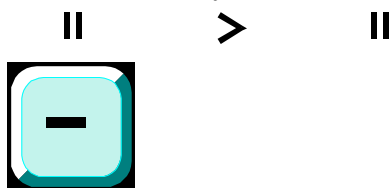

| | |
|-----------------------|---|
| - SHORT pressure | - Displays the duration of the programmed INITIAL PAUSE expressed in minutes. - During irrigation displays the INITIAL PAUSE remaining time. - In INITIAL PAUSE programming mode, single minute decrease. |
| - LONG pressure | - Enables programming the INITIAL PAUSE. (the symbol * on the left side of the display shows the beginning of the programming process). |
| - CONTINUOUS pressure | - In INITIAL PAUSE programming mode, fast minute decrease. |

SPEED key +

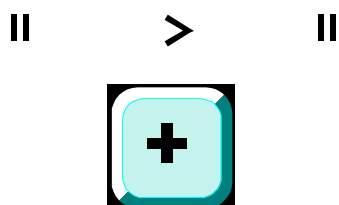

| | |
|-----------------------|---|
| - SHORT pressure | - Displays the programmed SPEED expressed in metres/hour (m/h). - In SPEED programming mode, single m/h increase. - In METRES unrolled pipe programming mode, single metre increase. - In IRRIGATION TIME programming mode, time increase. |
| - LONG pressure | - Enables programming the SPEED. (the symbol * on the left side of the display shows the beginning of the programming process). |
| - CONTINUOUS pressure | - In SPEED programming mode, fast m/h increase. - In METRES programming mode, fast metre increase. - In IRRIGATION TIME programming mode, fast time increase. |

SPEED key -

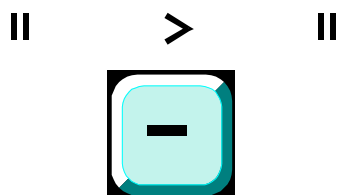

| | |
|-----------------------|---|
| - SHORT pressure | - Before the irrigation phase displays the programmed SPEED expressed in metres/hour (m/h). - During irrigation displays the instantaneous speed (im/h). - In SPEED programming mode, single m/h decrease. - In METRES unrolled pipe programming mode, single metre decrease. - In IRRIGATION TIME programming mode, time decrease. |
| - LONG pressure | - Enables programming the INITIAL PAUSE. (the symbol * on the left side of the display shows the beginning of the programming process). |
| - CONTINUOUS pressure | - In INITIAL PAUSE programming mode, fast minute decrease. - In METRES programming mode, fast metre decrease. - In IRRIGATION TIME programming mode, fast time decrease. |

FINAL PAUSE key +

|| > ||



| | |
|-----------------------|---|
| - SHORT pressure | - Displays the duration of the programmed FINAL PAUSE expressed in minutes. - In FINAL PAUSE programming mode, single minute increase. |
| - LONG pressure | - Enables programming the FINAL PAUSE. (the symbol * on the left side of the display shows the beginning of the programming process). |
| - CONTINUOUS pressure | - In FINAL PAUSE programming mode, fast minute increase. |

FINAL PAUSE key -

|| > ||



| | |
|-----------------------|--|
| - SHORT pressure | - Displays the duration of the FINAL PAUSE expressed in minutes. - During irrigation displays the FINAL PAUSE remaining time. - In FINAL PAUSE programming mode, single minute decrease. |
| - LONG pressure | - Enables programming the FINAL PAUSE. (the symbol * on the left side of the display shows the beginning of the programming process). |
| - CONTINUOUS pressure | - In FINAL PAUSE programming mode, fast minute decrease. |

Note: the display is backlit at every key pressure and remains lighted for about 8 seconds.

2.2 Regulation of the display's contrast

To facilitate the display's contrast regulation has been started up a direct control from the keyboard.

To increase the contrast you have to push at the same time for few seconds these 2 keys:

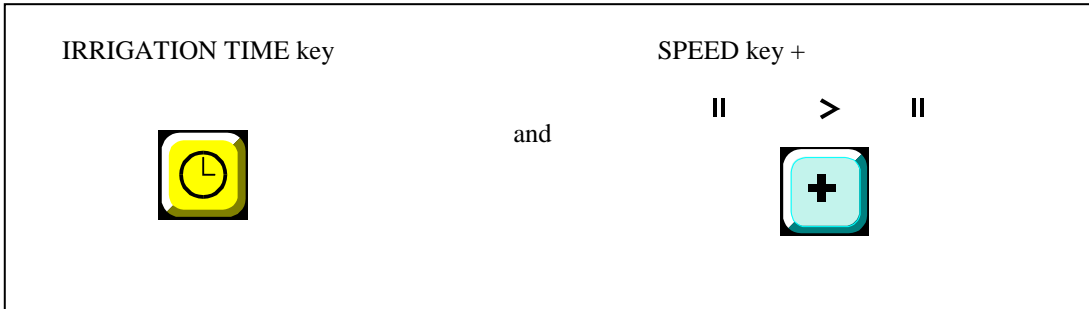

To decrease the contrast you have to push at the same time for few seconds these 2 keys:

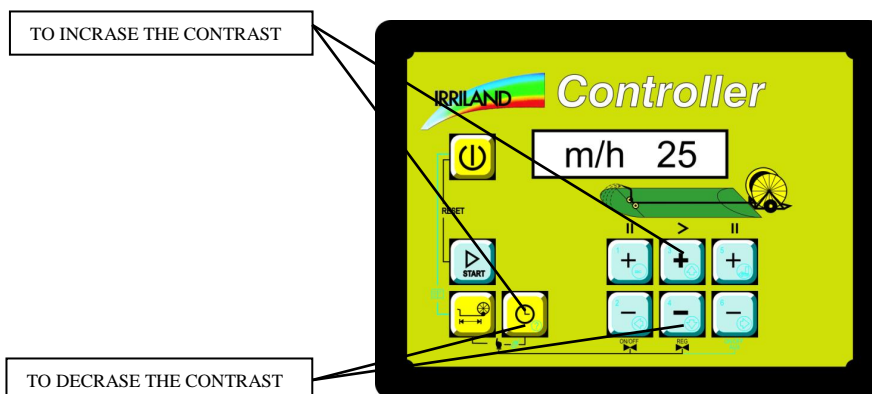
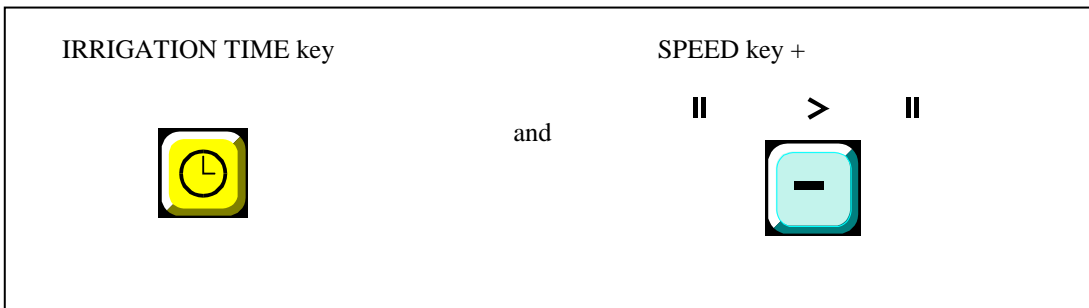

The new modifications are memorized directly.

2.3 CLOCK

The clock displays: day of the week and time in hours and minutes.
The clock is deactivated when the battery is disconnected.

2.3.1. Setting the day and time in hours and minutes.

To access the setting function for the day of the week and time in hours and minutes, enable the clock from the configuration menu [CLOCK YES], then proceed as follows:

| STEP | ACTION | DISPLAY | NOTES |
|------|--|---|---|
| 1 | turn off the control unit | [] | |
| 2 | Switch the control unit on by pressing and holding button h until, after a series of info screens, the text "TIME" is displayed (after a few seconds) | [IRRILAND] [CONTROLLER] [VER 1.68] [CLOCK---] [TIME?] [TIME] | - manufacturer name - model - software version - clock enabled - prompt message for access to clock function - access to clock function. |
| 3 | Release button h | [MO --:--] | - screen with day of the week and blank spaces for hours and minutes |
| 4 | Press button h | [MO* 0:00] | - asterisk appears. Modification enabled. |
| 5 | Press buttons + or – for Initial Pause to set day of the week. | [TH* 0:00] | - MO = Monday, TU = Tuesday etc |
| 6 | Press buttons + and – for speed setting to set hours from 0 to 23. | [TH*15:00] | |
| 7 | Press buttons + or – for Final Pause to set minutes from 0 to 59. | [TH*15:38] | |
| 8 | Press START to exit time setting function. | [GI*15:38] | |

With the clock function enabled, pressing **h** before unwinding and with a metre value of zero, the current time is displayed. After unwinding and during irrigation, the estimated day of the week and time in hours and minutes of end of irrigation are displayed.

2.4. Programming

To start programming Controller press the key of the feature to be programmed for at least one second till the symbol * appears: it enables programming the desired feature using the corresponding + and – keys.

2.4.1. Irrigation parameters

The irrigation parameters can be displayed or modified at any time.

To access the irrigation parameters press the corresponding key. If no key is pressed for 8 seconds, the controls return to the normal irrigation procedure.

It is possible to display the following parameters:

- METRES of unrolled pipe: enables manual setting and adjustment of metres of unrolled pipe between 0 and 999 m with 1-m steps by using **+** and **-** SPEED keys. [*m xxx] is shown on the display.
- Irrigation SPEED: enables setting the irrigation speed and then the pipe winding speed ranging between 3 and 999 m/h.
[m/h xxx] is shown on the display.
- INITIAL PAUSE: enables the static irrigation of the start header (there is no trolley retraction). It is activated pressing **START** key. The Initial Pause can be programmed ranging between 0 and 99 minutes.
- FINAL PAUSE: enables the static irrigation of the final header, starts when the rewinding limit switch is activated. The Final Pause can be programmed ranging between 0 and 99 minutes.
- Irrigation TIME: enables setting the irrigation time including Initial and Final PAUSE. The variation of the irrigation time automatically changes the rewinding speed leaving pauses unchanged. The time can be set between 0 and 99.59 hrs consistently with pauses and metres of unrolled pipe, with variations of one minute or more.

3. IRRIGATION CYCLE

For a correct irrigation procedure respect the following phase sequence:

| PHASE | DESCRIPTION |
|-------|---|
| 1 | - switch on the control box |
| 2 | - unroll the pipe. Metres of unrolled pipe are displayed |
| 3 | - program the rewinding speed as desired. - program Initial and Final Pause. |
| 4 | - start irrigation cycle pressing START key. |
| 5 | - End of irrigation cycle. - Switch off the control box. |

3.1 Switching on the Controller control box

Press **ON/OFF** key

to switch on the control box. The display is lighted and the following information appears in sequence:

| N° | DISPLAY | MEANING | BACKLIGHTING STATUS |
|----|----------------|-----------------------------|---------------------|
| 1 | [_____] | All segments of display lit | (ON) |
| 2 | [IRRILAND] | Manufacturer Name | (ON) |
| 3 | [CONTROLLER] | controller type | (ON) |
| 4 | [Ver. X.XX] | program version | (ON) |
| 5 | [OPEN] | Valve position | (ON) |
| 6 | [<- m 0] | amount of unrolled metres | (OFF) |

Note: if the clock is enabled [CLOCK YES] but has not been programmed, the message [CLOCK ---] is displayed between screens 4 and 5.

The flow valve motor places the valve in the correct position depending on the mounting position of the valve in respect to the water flow: inlet or outlet.

When the valve moves [OPEN] is displayed when in inlet position, [CLOSE] is displayed when in outlet position.

When the desired position is reached [OK] is displayed.

The speed regulation motor is positioned at 0 or minimum speed. When the motor is starting [REG --] is displayed. When the desired position is reached [REG OK] is displayed.

This operation ends the switching on phase and the Controller remains waiting for the pipe to be unrolled or resumes the interrupted cycle.

If the previous cycle had been interrupted and you wish to start a new cycle instead of resuming the interrupted one press **START** key during switching on and keep it pressed till ' RESET ' is displayed: the interrupted cycle is dropped and a new cycle is starting.

3.2 Unrolling of the pipe

The pipe must be unrolled after the switching on phase is finished and before pressing **START** key for at least 1 second

During the unrolling process the control box measures the amount of metres of unrolled pipe.

On the screen the amount of unrolled pipe is displayed, e.g. [<-m 358].

IMPORTANT

Check that the displayed amount is correct.

If the displayed amount is not correct manually change the displayed value.

If the pipe is unrolled without switching on the Controller it is necessary to manually enter the amount of unrolled metres to obtain the exact number of remaining metres and the irrigation time.

3.2.1. Manual change or entry of the amount of unrolled metres

To enter or change the amount of unrolled metres do the following operations in the following order:

| Phase | operation | display | remarks |
|-------|--|------------------------|--|
| 0 | situation after switching on | [<-m 0] | - Backlighting off |
| 1 | press M key for at least 1 second | [* m 0] | - The symbol * appears - Backlighting on |
| 2 | Press + or - key to change the amount of metres as desired e.g. m 352 | [* m 352] | - Backlighting on |
| | +1 > + | [* m 345] | - continuous pressure |
| | +1 > + | [* m 352] | - single pressures - If the number of pressures is not correct use - key to make adjustments |
| 3 | Press another key to confirm and pass to another feature. e.g. irrigation TIME key h Or wait 8 secs to go back to irrigation frame. | [h hh:mm] [<-m 352] | - Backlighting on - Backlighting off |

NOTE:

- 1 In programming mode, if no key is pressed for 8 seconds, the displays goes back to the irrigation frame and the last displayed datum is confirmed.
- 2 The amount of unrolled metres can be modified also during irrigation.
- 3 The smallest unit you can change is metre.

3.3 Programming the Winding Speed

The winding speed should be programmed after the switching on phase is finished and before pressing **START** key.

The rewinding speed can be modified also during the irrigation phase.

To program or change the rewinding speed do the following operations in the following order:

| Phase | operation | display | remarks |
|-------|--|------------------------|--|
| 1 | > Press + key (short pressure) | [Pm/h 30] | - Last programmed speed. - Backlighting on |
| 2 | > Press + key (1 sec.) or - key to enable the change | [*m/h 30] | - - The symbol * on the left enables the change - Backlighting on |
| 3 | Keep + or - key pressed till the desired speed e.g. m/h 35. Use + or - key to make adjustments, exerting short or continuous pressures | [*m/h 35] | |
| 4 | Press another key to confirm and pass to another feature e.g. irrigation TIME key h Or wait 8 secs to go back to irrigation frame | [h hh:mm] [<-m 352] | - Backlighting on - Backlighting off |

NOTE:

1. In programming mode, if no key is pressed for 8 seconds, the displays goes back to the irrigation frame.
2. The programmed speed can be modified also during irrigation.
- 3 After a long pressure of **+** or **-** key the symbol * is displayed and the increase or decrease of the value immediately starts.

3.4 Programming the Initial Pause

The Initial Pause should be programmed after the switching on phase is finished and before pressing **START** key.

To program or change the Initial Pause do the following operations in the following order:

| Phase | operation | display | remarks |
|-------|---|--------------------------|--|
| 1 | Press + key (short pressure) | [PI 0'] | - Last programmed pause. - Backlighting on. |
| 2 | Press + key (1 sec) or - key to enable the change | [*PI 0'] | - The symbol * on the left enables the change - Backlighting on |
| 3 | Keep + or - key pressed till the desired value for the Initial Pause, e.g. 15 minutes. Use + or - key to make adjustments exerting short or continuous pressures. | [*PI 15'] | - The symbol * enables the change - Backlighting on |
| 4 | Press another key to confirm e.g. irrigation TIME h key or wait 8 secs to go back to irrigation frame | [h hh:mm] [<-m 352.0] | - Backlighting on - Backlighting off |

NOTE:

1. In programming mode, if no key is pressed for 8 seconds, the displays goes back to the irrigation frame.
2. The programmed speed and pauses which have not been completed yet can be modified also during irrigation.
2. After a long pressure of **+** or **-** key the symbol * is displayed and the increase or decrease of the value immediately starts.

3.5 Programming the Final Pause

The Final Pause should be programmed after the switching on phase is finished and before pressing **START** key.

To program or change the Final Pause do the following operations in the following order:

| phase | operation | display | remarks |
|-------|---|--------------------------|--|
| 1 | Press + key (short pressure) | [PF 0'] | - Last programmed pause - Backlighting on |
| 2 | Press + key (1 sec) or - key to enable the change | [*PF 0'] | - The symbol * on the left enables the change - Backlighting on |
| 3 | Keep + or - key pressed till the desired value for the Final Pause, e.g. 15 minutes. Use + or - key to make adjustments exerting short or continuous pressures. | [*PF 15'] | - The symbol * on the left enables the change - Backlighting on |
| 4 | Press another key to confirm e.g. irrigation TIME key h or wait 8 secs to go back to irrigation frame | [h hh:mm] [<-m 352.0] | - Backlighting on - Backlighting off |

NOTE:

1. In programming mode, if no key is pressed for 8 seconds, the displays goes back to the irrigation frame.

2. The programmed speed and pauses which have not been completed yet can be modified also during irrigation.
3. After a long pressure of **+** or **-** key the symbol * is displayed and the increase or decrease of the value immediately starts.

3.6 Programming the Irrigation Time

After the pipe has been unrolled and metres have been programmed, it is possible to program the Irrigation Time. Controller automatically calculates the trolley retraction speed depending on the amount of metres of unrolled pipe and on any programmed time in the Initial and Final Pause.

This programming process can be carried out during the Irrigation Cycle as well.

To program the Irrigation Time do the following operations in the following order:

| phase | operation | display | remarks |
|-------|---|----------------------------|--|
| 1 | Press h key (1 sec) | [*h 12:05] | - Calculated time. - The symbol * on the left enables the change - Backlighting on |
| 2 | Press + key to increase the time or press - key to decrease the time. | [*h 12: 30] [*h 11: 20] | - The symbol * on the left enables the change - Backlighting on |
| 3 | Press h key (or another key). Or wait for the backlight to go out (8 secs). | [h 12: 30] [<-m 358] | - The symbol * disappears - Backlighting on - Irrigation frame - Backlighting off |
| 4 | Press + key to check speed variation | [Pm/h 45] | - Backlighting on |

NOTE:

1. In programming mode, if no key is pressed for 8 seconds, the displays goes back to the irrigation frame.
2. The remaining irrigation time can be modified also during irrigation.

3.7 Start of the Irrigation Cycle

Press **START** key to start the Irrigation Cycle. [START] appears on the display.

Controller now actuates the flow valve, starts the static irrigation for the time programmed in the Initial Pause and then starts the regulation motor to start rewinding the pipe.

3.7.1 Displays during irrigation

During the Irrigation Cycle the following displays are shown:

| | |
|---|--------------|
| remaining time of the Initial Pause (if programmed) | [rI 8'] |
| at starting, with no impulse | [m/h ____] |
| when the motor is starting | [REG +] |
| after the first impulse | [m/h 0] |
| with following impulses | [im/h 12] |
| speed measured as instantaneous value | [im/h 35] |
| speed measured at running condition | [m/h 32] |

During irrigation the display normally shows the retraction speed.

When the regulation motor is started, during the initial phase, on the screen [REG +] is displayed for 1 second [REG +] symbolizes a regulation to increase the speed.

[REG -] symbolizes a regulation to decrease the trolley retraction speed.

During the irrigation phase, where the speed is stable, small adjustments carried out by the motor are displayed with a + or - symbol before the speed value, e.g. [+ m/h 32] or [- m/h 32].

When a **+** key is pressed the corresponding programmed feature is displayed.

e.g. [PI 15'] for the Initial Pause,
[PF 10'] for the Final Pause and
[Pm/h 30] for the Speed

When a **-** key is pressed:

- when pauses are concerned, the remaining minutes of the corresponding pause are displayed

e.g. [rI 6'] for the Initial Pause,
[rF 8'] for the Final Pause.

- when speed is concerned, the instantaneous speed is displayed:

e.g. [im/h 52] the symbol "i" means instantaneous.

3.7.2 Possible anomalies during Irrigation Cycle

Here is a list of the displays which can be shown during the Irrigation Cycle due to particular or improper operating conditions:

[ZERO m]

is displayed when **START** key is pressed with an amount of unrolled metres equal to 0 or to a negative value. The irrigation starts but the values for the time and for the metres are not correct. Program the amount of metres of unrolled pipe.

[END ERR]

is displayed when **START** key is pressed and the rewinding limit switch sensor contact is activated (closed). The irrigation does not start. Deactivate the sensor by opening the contact and then press **START** key to start irrigation

[REG ?]

is displayed when the regulation motor reaches the limit of its valve closing rotation. The irrigation continues in any case.

This condition may occur when the gear engaged in the irrigator is not suitable to the programmed speed or the irrigator cannot operate at the programmed speed.

[E m/h 0] (i.e. SPEED ERROR =0)

is displayed when no impulse reaches the speed sensor over a certain span (this time depends on the programmed speed). Controller interrupts the irrigation by appropriately operating the valves and alternately displaying [E m/h 0] and [SW OFF].

[PRESS 0]

If the pressure drops to activate the pressure switch (if mounted), Controller displays [PRESS 0] setting the regulation motor speed at 0. It will also actuate the flow motor depending on the position of the flow valve: the valve is not actuated if mounted in outlet position, the valve is closed to interrupt irrigation if mounted in inlet position. This display remains till pressure goes back to the proper value; at that point Controller resumes the regulation.

3.8 End of the Irrigation Cycle

The End of Irrigation Cycle phase starts when the rewinding limit switch is activated. The regulation motor is then actuated in 0 speed position and, if programmed, the static irrigation of the Final Pause starts. For the programmed time the remaining time is displayed, e.g. [rF 5'].

When the time of the Final Pause has elapsed Controller actuates the flow valve to end irrigation. This operation depends on the position of the valve:



Once completed the operation of the valve Controller energizes the 1-exchange relay on the card for 30 seconds.

To start a new irrigation cycle switch off and then restart Controller control box.

4. TEST and MANUAL PROCEDURE

The test procedure enables testing the gear motors connected to Controller and the relay mounted on the card. To access this procedure press METRES key **_m_** and IRRIGATION TIME key **_h_** simultaneously at any time with the equipment switched on. Once you have accessed this mode [MANUAL] is displayed on the screen.

4.1 Outlet test

Flow valve motor

A short pressure on **+_** key of the Initial Pause manually operates the flow valve in opening direction and [OPEN] is shown on the display. The motor keeps running till a complete revolution is carried out; to stop it exert a short pressure on **+_** or **-_** key. In this case [MOT STOP] is shown on the display.

A short pressure on **-_** key of the Initial Pause manually operates the flow valve in closing direction and [CLOSE] is shown on the display. The motor keeps running till a complete revolution is carried out; to stop it exert a short pressure on **+_** or **-_** key. In this case [MOT STOP] is shown on the display.

Note :

- 1) if **+_** or **-_** key is pressed the motor is starts moving. If the key is pressed again the motor is stopped.
- 2) **IMPORTANT!** If, during operation, the test function is selected while the valve motor is in motion, control over the valve motor switches to manual mode. After exiting the test, the motor stops even if it has not completed its travel. To prevent this from happening, wait for the motor to complete the manoeuvre before selecting the test function.

Regulation valve motor

If **+_** or **-_** key of the Speed is pressed the regulation valve is manually operated.

The **+_** key starts the motor increasing the speed and [SPEED RG+] is shown on the display.

The **-_** key starts the motor decreasing the speed and [SPEED RG-] is shown on the display.

Note : the motor keeps running as long as the key is kept pressed. The motor stops when the key is released or when it reaches its end of stroke.

Relay and OUTPUTS

If **+_** or **-_** key of the Final Pause is pressed the relay or the Outputs is manually operated.

If **+_** key is pressed the relay is energized and [RELAY ON] or [OA1 ON] or..... is shown on the display.

If **-_** key is pressed the relay is de-energized and [RELAY OFF] or [OA1 OF] or... is shown on the display.

To exit TEST mode press **START** key.

4.2 Test of battery voltage, sensors, relays, input and output extra sources.

Press again the METERS **_m_** button to display on the screen the actual status of the sensors, relays, input and output extra sources and eventually run a test on them.

The settings appear in the following order:

| Fase | Display | Note |
|------|-----------------|--|
| 0 | [MANUAL] | A splash screen shows that it enters "test" mode. |
| 1 | [12.4V 0.0A] | Shows battery supply voltage (V) and current (A) used by the engines |
| 2 | [SPEED OF] | Shows the status of the speed sensor: open contact = sensor de-excited. The display shows [SPEED OF]. closed contact = sensor excited. The display shows [SPEED ON]. |
| 3 | [PRESS OF] | Shows the status of the pressure sensor: open contact = pressure is present. The display shows[PRESS OF] closed contact = pressure is absent. The display shows[PRESS ON] |
| 4 | [END OF] | Shows the status of the sensor of rewinding end: open contact = sensor de-excited. The display shows [END OF]. closed contact = sensor excited. The display shows [END ON]. |
| 5 | [4 – 20 -- %] | Analogue input used for the pressure transducer (see § connections). |



| | | |
|----|--------------|--|
| 6 | [IAUX OF] | Shows the status of auxiliary input. Reserved for the anemometer (see § connections). |
| 7 | [IA1 OF] | Shows the status of auxiliary 1 input. Accepts remote Start or Stop irrigation commands (see § connections). |
| 8 | [IA2 OF] | Shows the status of auxiliary 2 input. Accepts remote Start or Stop irrigation commands (see § connections). |
| 9 | [RELAY OF] | Shows the relay status. If + or - key of the Final Pause is pressed the relay is manually operated. If + key is pressed the relay is energized and [RELAY ON] is shown on the display. If - key is pressed the relay is de-energized and [RELAY OFF] is shown on the display. Note: when you exit TEST mode, in case of [RELAY ON], the relay is DE-EXCITED. |
| 10 | [OA1 OF] | Shows the status of auxiliary output 1. Reserved for controlling a valve for a small end of field nozzle. Press buttons + or - for Final Pause to control the output manually. |
| 11 | [OA2 OF] | Shows the status of auxiliary output 2. Reserved for input/output valve selection. Press buttons + or - for Final Pause to control the output manually. |
| 12 | [OA3 OF] | Shows the status of auxiliary output 3. Reserved for controlling an unwinding warning indicator with metre setting. Press buttons + or - for Final Pause to control the output manually. |
| 13 | [C 0] | Speed sensor impulse counter. |
| 14 | [MANUAL] | Back to the splash screen. |

Press START button to exit TEST mode or wait 3 minutes and it exits automatically if no key is pressed.

Note: if the anemometer and/or pressure transducer are enabled, the relative screens shown below are displayed between steps 1 and 2:

| | | |
|----|-------------|---------------------|
| 1a | [VE 3 Kmh] | Wind speed in Km/h. |
| 1b | [BAR 8.3] | Air pressure in Bar |

5. CONNECTIONS

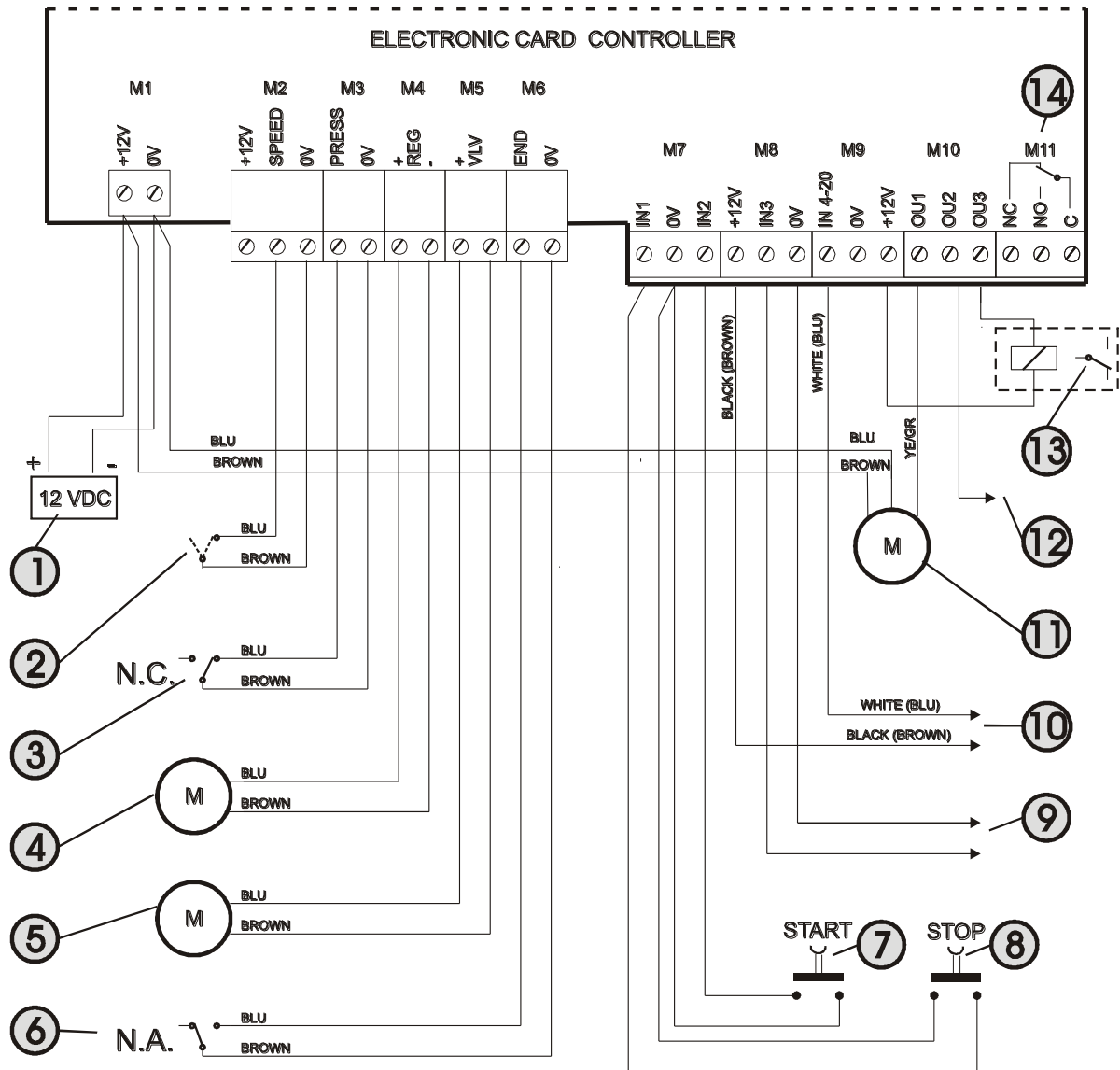

| STANDARD CONNECTIONS | |
|-----------------------|--------------------------------------|
| 1 | 12VDC BATTERY |
| 2 | INDUCTIVE OR MAGNETIC SPEED SENSOR |
| 3 | PRESSURE SWITCH |
| 4 | ADJUSTMENT MOTOR |
| 5 | FLOW MOTOR |
| 6 | END REWINDING SENSOR |
| AUXILIARY CONNECTIONS | |
| 7 | AUXILIARY START CONTROL |
| 8 | AUXILIARY STOP CONTROL |
| 9 | ANEMOMETER |
| 10 | PRESSURE TRANSDUCER |
| 11 | MOTORIZED VALVE FOR END FIELD JET |
| 12 | SELECTION FOR OUTLET OR INTAKE VALVE |
| 13 | 'WARNING RELE' FOR UNROLLED METRES |
| 14 | ENGINE OR MOTOPUMP SWITCH OFF RELE' |

6. REGULATIONS

Controller control box complies with regulations CEI 61-33, CEI EN 60335-2-60 in force.